



CGR-100 and CGR-101 Analog State of Charge Meter Installation Instructions

Before You Start

1. Turn the key to the OFF position.
2. Place the TOW/RUN switch in TOW.
3. Engage the parking brake.

Install State of Charge Meter

1. Find a location on the dash to mount the state of charge meter.
2. Mark the center of the mounting location with a marking device.
3. Drill or cut the marked area. Test fit the meter. Make any adjustments with a file.

CAUTION: Look behind the mounting location BEFORE you drill or cut. Installer is responsible for damage.

4. File any rough edges.
5. Mount the charge meter securely to the dash of the vehicle using the Hardware Included with the Meter.
6. Connect the meter using the diagram on the reverse side.

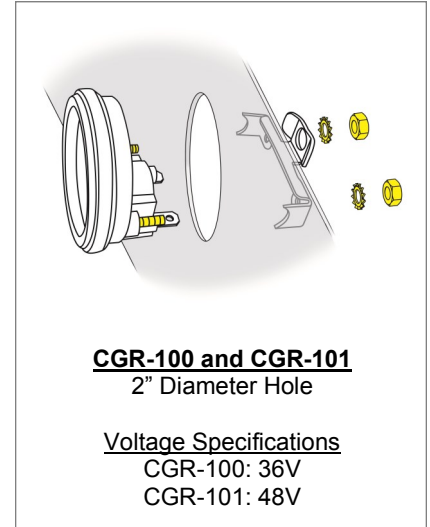

Analog State of Charge Meters

1. Connect leads to meter as shown.
2. Connect the leads to battery pack. Battery layouts are for reference only. Battery configurations may vary.

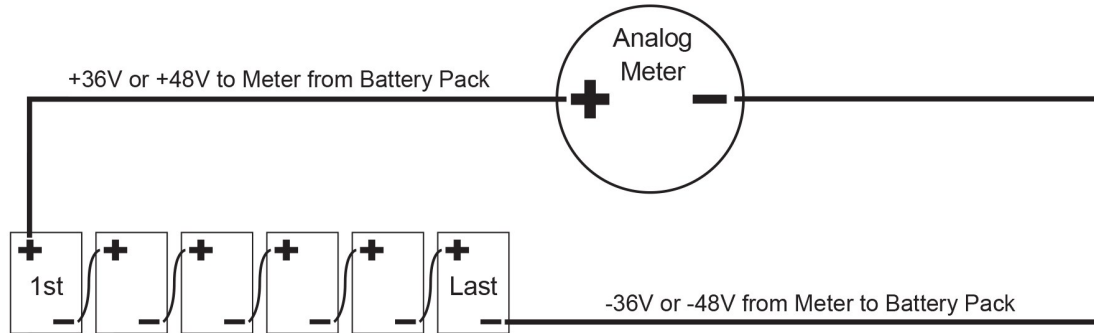

The installation is now complete.
Please enjoy safely!