

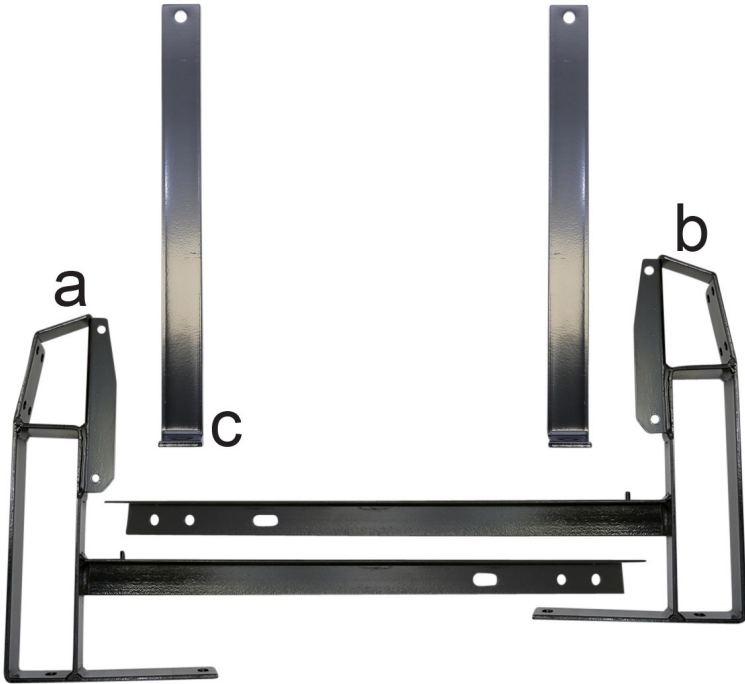

RHOOX

Rugged parts for your ride.

BOX-118 E-Z-Go TXT Utility Box Mounting Kit Installation Instructions



Contents of BOX-118 Utility Box Mounting Kit:

- a (1 ea.) Utility Box Support Frame, Driver Side
- b (1 ea.) Utility Box Support Frame, Passenger Side
- c (2 ea.) Vertical Support Brackets
- d (1 ea.) Latch Kit (Contents on Next Page)
- e (1 ea.) Box of Hardware (Contents on Next Page)

Caution: Please read through the instructions carefully. Installer is responsible for damage if instructions are not followed properly. Look behind each drill or cut location BEFORE YOU DRILL OR CUT. Installer is responsible for damage (i.e. drilling/cutting into a wiring harness, battery, fuel tank etc.). Extra installers will be helpful in some parts of the installation. Refer to vehicle's maintenance manual for torquing specifications on reused hardware.

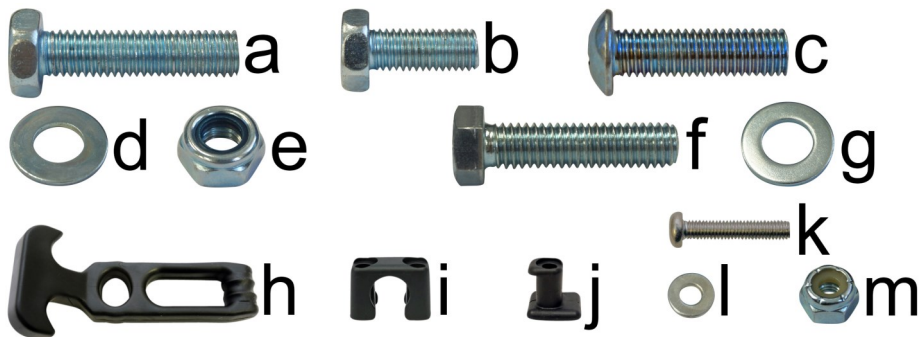

| Contents of BOX-118 Hardware Kit and Latch Kit | | Qty. |
|------------------------------------------------|---------------------------------------------|------|
| a | 10mm-1.5 x 40 Hex Head Bolts | 2 |
| b | 10mm-1.5 x 25 Hex Head Bolts | 2 |
| c | 10mm-1.5 x 35 Phillips Head Truss Bolts | 4 |
| d | 10mm Flat Washers | 12 |
| e | 10mm-1.5 Nylock Nuts | 8 |
| f | 3/8-16 x 1.5" Hex Head Bolts | 4 |
| g | 3/8" Flat Washers | 4 |
| h | Latches | 2 |
| i | Latch Mounting Brackets | 2 |
| j | Latch Catches | 2 |
| k | 10-32 x 1" Pan Head Phillips Machine Screws | 6 |
| l | #10 Flat Washers | 6 |
| m | 10-32 Nylock Nuts | 6 |

NOTE: The Utility Box Mounting Kit is universal for the RHOX line of Utility Boxes. Depending on the style of utility box being installed, all of the hardware may not be used.

Tools Needed For Installation

- Sockets and Open Ended Wrenches: 7/16", 1/2", 9/16", 17mm
- Phillips Screwdriver
- Drill and Drill Bits (small bit for pilot holes, 7/16")

Installation Preparation

1. Engage parking brake.
2. Turn key OFF.
3. Electric Carts Only: Place Tow/Run Switch in Tow.
4. Remove top.

NOTE: If reinstalling the top, keep the top attached to the front struts and prop up the rear of the top using a broom handle or similar tool. Retain hardware.

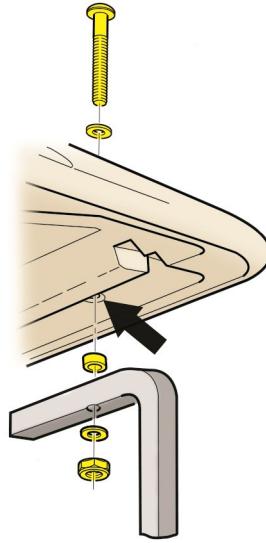

Rear Strut (Driver Side)

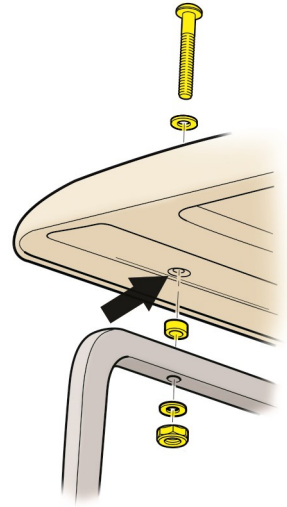

Front Strut (Driver Side)

5. Remove the front seat back cushion (black arrows). Retain hardware.
6. Remove rear struts (red arrows). Retain hardware.

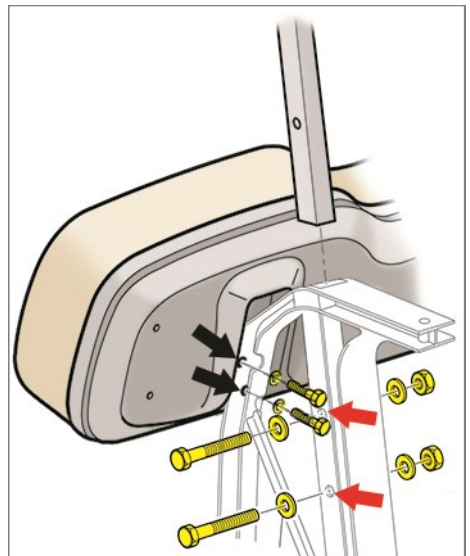

(Driver Side)

7. Remove both seat back supports and the bag attachment. Driver side seat support shown.

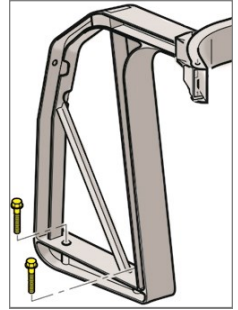

Utility Box Mounting Kit Installation

1. Use a 7/16" drill bit to open up the (2) holes in the bagwell area. Drill completely through the rivet (if present) and frame.

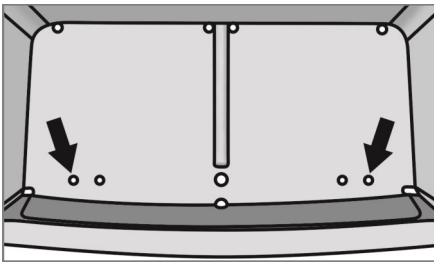

TXT 1996-2013

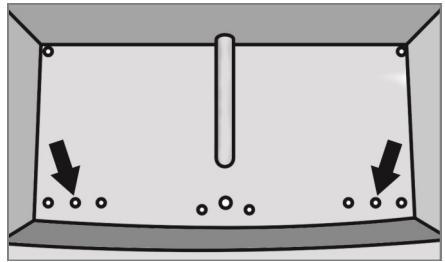

TXT 2013+

2. Loosely fasten the vertical support brackets to the bagwell area using (2) 10mm x 40 Hex Head Bolts, (4) 10mm Flat Washers and (2) 10mm Nylock Nuts.

NOTE: The feet on the brackets should face towards each other.

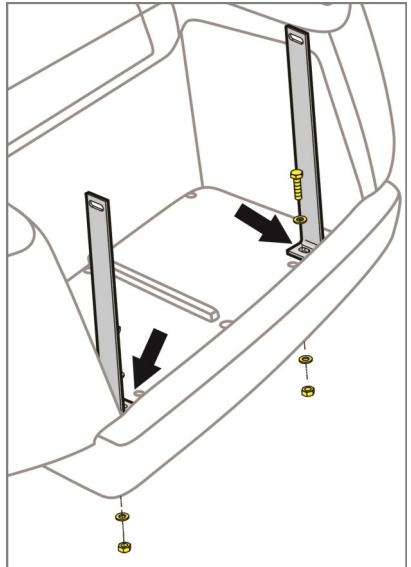

- Loosely fasten the utility box support frames where the original seat back supports were installed using (4) 3/8-16 x 1-1/2" Hex Head Bolts and (4) 3/8" Flat Washers (black arrows).

NOTE: Driver and passenger side brackets are different. Orient as shown.

- Fasten the vertical support brackets to the utility box support frames using (2) 10mm x 25 Hex Head Bolts, (4) 10mm Flat Washers and (2) 10mm Nylock Nuts (red arrows).
- Fasten the original seat back to the utility box support frames using the Original Hardware removed on Page 3 (blue arrows).
- If reinstalling the OE rear struts, install them to the utility box support frame using the Original Hardware (green arrows).
- Reinstall the top using the Original Hardware (if applicable).

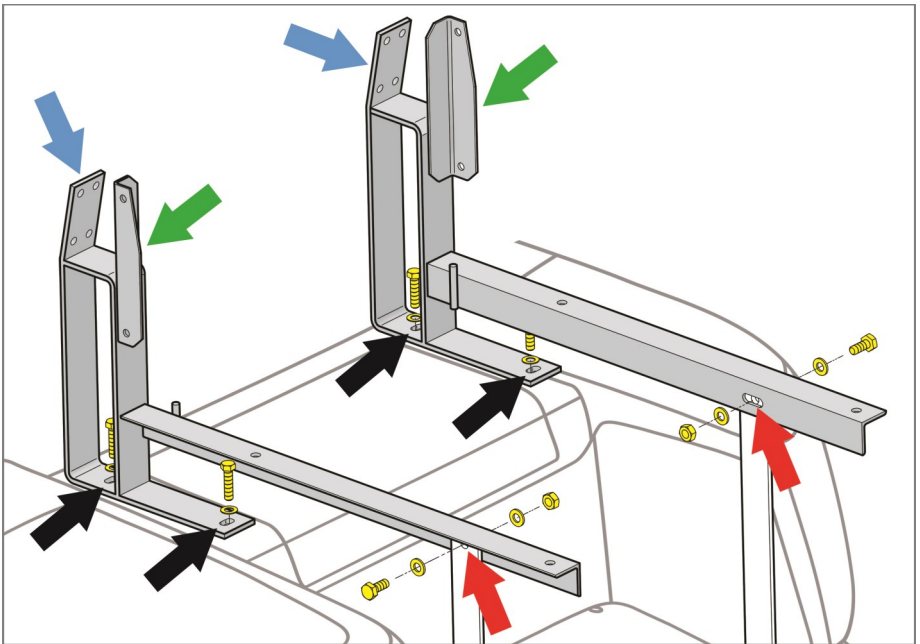

RHOX Thermoplastic and Poly Utility Box Installation

1. Place the utility box on top of the utility box support frames so the tailgate is towards the rear of the cart. Align the (4) mounting holes with the (4) holes on the support frames.
2. Fasten the utility box to the support frames using (4) Hardware Cap Sets, (4) 10mm x 35mm Phillips Head Truss Bolts, (4) or (8) Flat Washers, depending on the box style, and (4) Nylock Nuts.
3. Tighten all hardware.

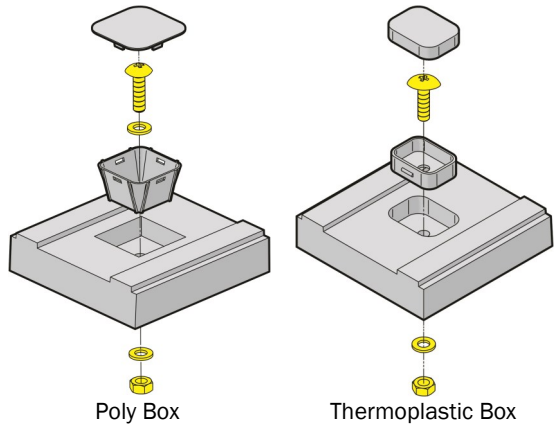

RHOX Steel and Aluminum Utility Boxes

1. Place the utility box on top of the support frames so the tailgate is at the rear of the cart.
2. Push the utility box towards the front of the cart until it touches both alignment pins.
3. Center the box between the driver and passenger sides of the cart.
4. Using a marking device, mark the (4) hole locations onto the underside of the utility box.
5. Remove the box from the cart and place it upside-down on a clean piece of cardboard to avoid damage.
6. Use a center punch to make a dimple at each of the (4) marked locations. Use a small drill bit to drill a pilot hole. Work up to a 7/16" drill bit for the final hole size. Remove any burrs with a small file.

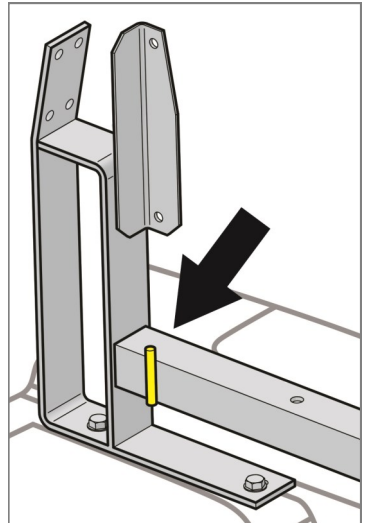

7. Fasten the utility box to the support frames using (4) 10mm-1.5 x 35mm Phillips Head Truss Bolts, (4) 10mm Flat Washers and (4) 10mm-1.5 Nylock Nuts.

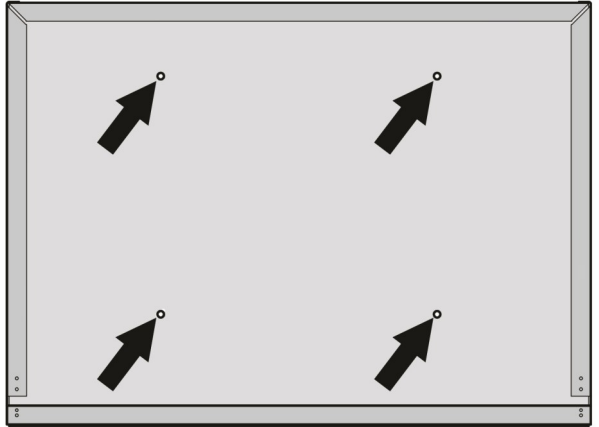

8. Fasten the latch catches to the tailgate using (2) 10-32 x 1" Pan Head Phillips Machine Screws, (2) Flat Washers and (2) Nylock Nuts (black arrow).

NOTE: Orient the latch catch as shown:



9. Fasten the latch brackets to the upper lip of the utility bed using (4) 10-32 x 1" Pan Head Phillips Screws, (4) Flat Washers and (4) Nylock Nuts (Red Arrow).

10. Tighten all hardware.

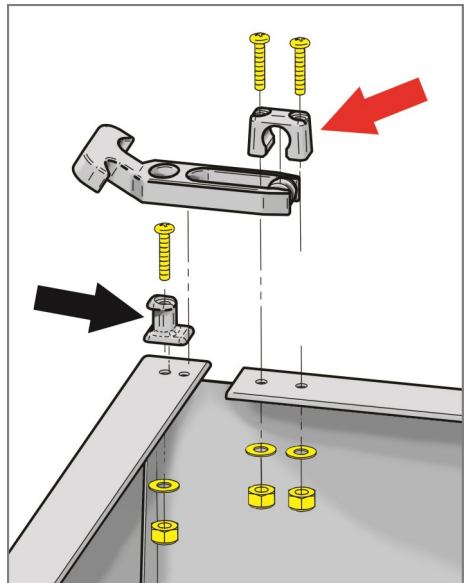

This completes the installation of your RHOX Utility Mounting Kit and Utility Box. Please enjoy safely!

Scan QR code or use the link below to view the installation video.

<https://vimeo.com/user39935056>



**RUGGED
STARTS
HERE**

